

NOTE: Please attach a rough draft drawing of your driveway plan and return it with your driveway application.



7125 Riverwood Drive
Columbia, MD 21046
Highways@howardcountymd.gov
PH (410) 313-7450
FAX (410) 313-7260

ENTRANCE APPLICATION & PERMIT

HOWARD COUNTY

Permission is hereby requested from the Howard County Department of Public Works, Bureau of Highways, for an entrance permit: (Section 18.206, Howard County Code)

Owner/Applicant: _____ Phone: (____) _____

Address: _____

Location of entrance: _____

For what use: _____ Residential _____ Commercial

The applicant hereby certifies and agrees as follows: (1) that he is the owner or the duly authorized agent of the owner to make this application; (2) that he has read all of the information set forth and that the same is correct; (3) that the permit, when issued, may be declared void should said information be incorrect; (4) that he will comply with all rules and regulations of Howard County Bureau of Highways; (5) that he will perform the work on the entrance in conformance with the County's standards and specifications.

Signed: _____ Date: _____
(Applicant)

It is agreed and understood by the acceptance of this permit, the following conditions will be followed. (Section 18.207, Howard County Code)

- A. The construction of the entrance or approach will in no way change the grade and/or alignment of any existing drainage facility or structure. In the event same are damaged or destroyed, they shall be replaced to the satisfaction of the Howard County Department of Public Works, Bureau of Highways Representative.
- B. The right-of-way affected by this permit will be left in a neat and clean condition and no excess material will be permitted to remain on or adjacent to the right-of-way. Shoulders and flow-line areas disturbed shall be restored according to the Howard County Standards and Specifications.
- C. A bond to guarantee the satisfactory completion of the work may be required.

Approved: _____ Date: _____
(Title)

In consideration of the issuance of this permit, the applicant agrees that if he fails to comply with the above set-out standards and thereby causes damage to the Howard County Road System, that the applicant will be responsible to Howard County for such damage to its road system.

ATTENTION: This permit, when issued, is valid for a period not to exceed one year.
PWH-65-94-03

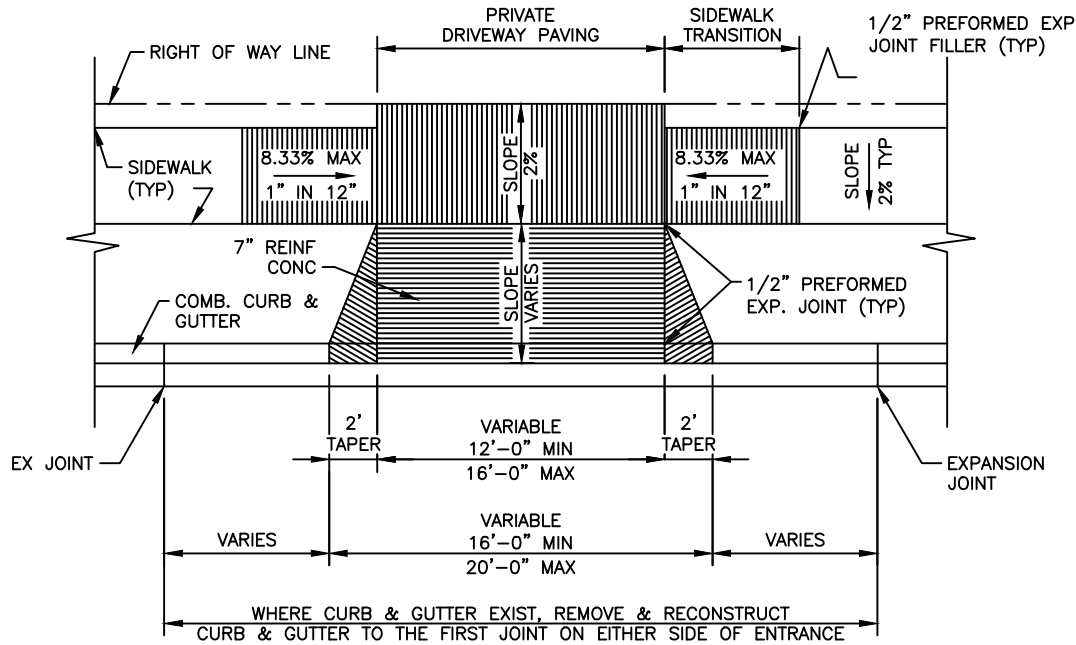

PLAN

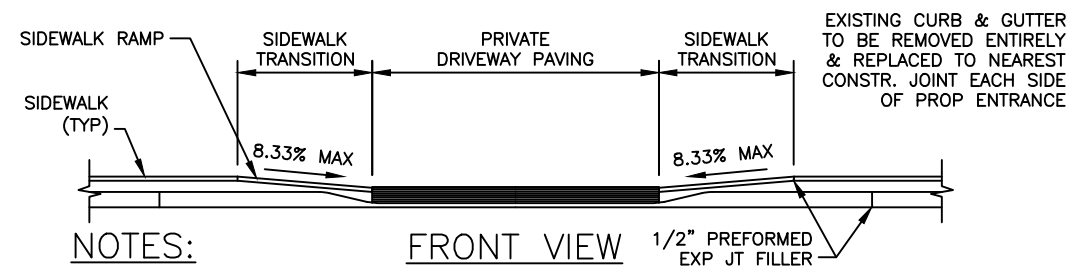

FRONT VIEW

NOTES:

1. PRIVATE DRIVEWAY (IF CONC, 1/2" PREFORMED EXP JT IS TO BE PROVIDED AT R/W LINE.)
2. TIE-IN GRADE OF PRIVATE DRIVEWAY SHALL NOT EXCEED 15%.
3. ALL RAMPS SHALL HAVE A TEXTURE EXTENDING THE FULL WIDTH AND DEPTH OF THE RAMP. GRASS AREA ADJACENT TO SIDEWALK MUST BE SLOPED TO MEET RAMP.
4. SIDEWALK LESS THAN 5'-0" REQUIRES APPROVAL THROUGH THE EXCEPTIONS PROCESS; SEE VOLUME III.
5. THE WIDTH OF THE ADJACENT SIDEWALK, SHARED USE PATH, AND/OR SEPARATED BIKEWAY SHALL BE CONTINUED ACROSS THE DRIVEWAY.

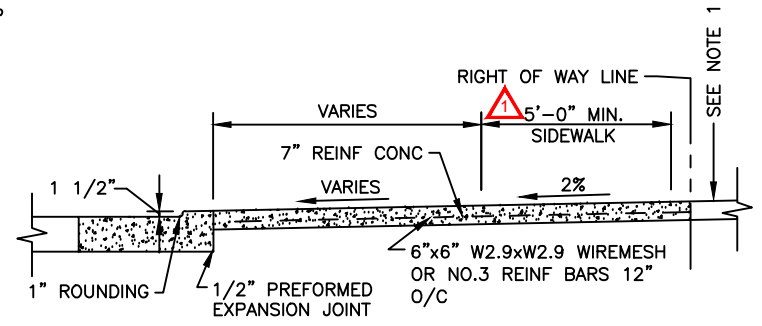

SECTION DRIVEWAY IN NEW CURB

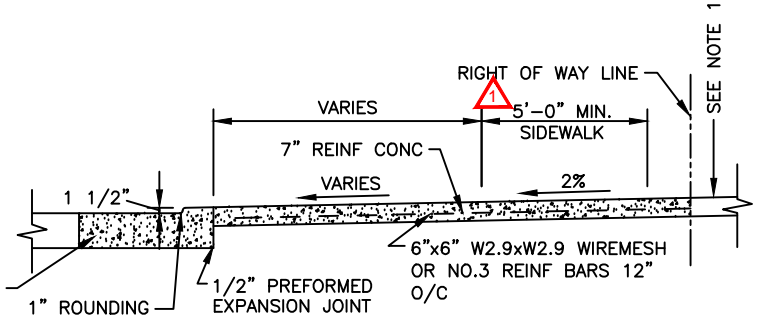

SECTION DRIVEWAY IN EXISTING CURB

2/7/2022
Revised
5/30/2017
Approved
5/7/2007
Approved

Howard County, Maryland
Department of Public Works
Approved: *Thomas E. Butler*
Chief, Bureau of Engineering

RESIDENTIAL DRIVEWAY ENTRANCE
7" Combination Curb and Gutter
Sidewalk Setback from Curb

Detail
R-6.01

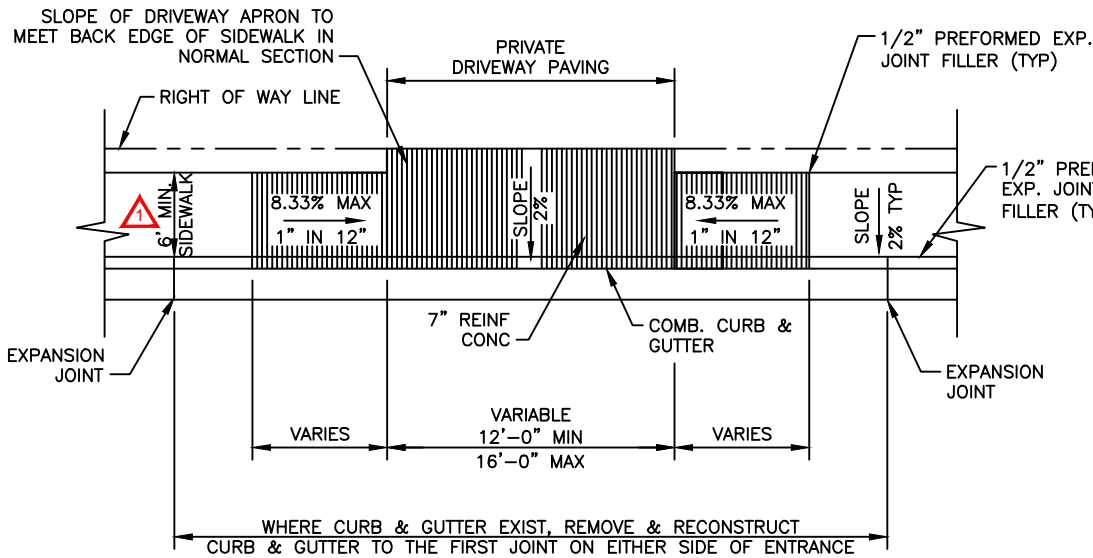

PLAN

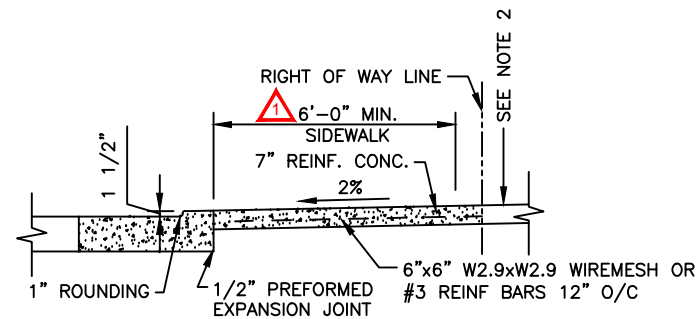

SECTION DRIVEWAY IN NEW CURB

EXISTING CURB & GUTTER TO BE REMOVED ENTIRELY & REPLACED TO NEAREST CONSTR. JOINT EACH SIDE OF PROP ENTRANCE

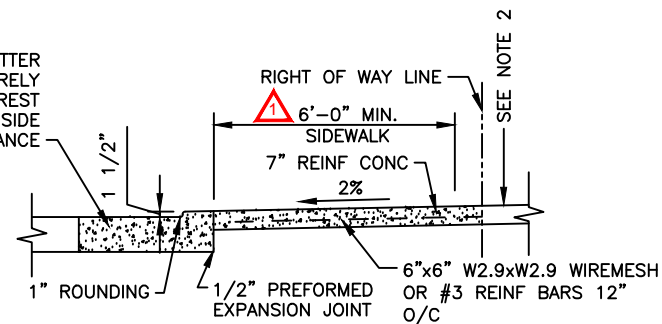

SECTION DRIVEWAY IN EXISTING CURB

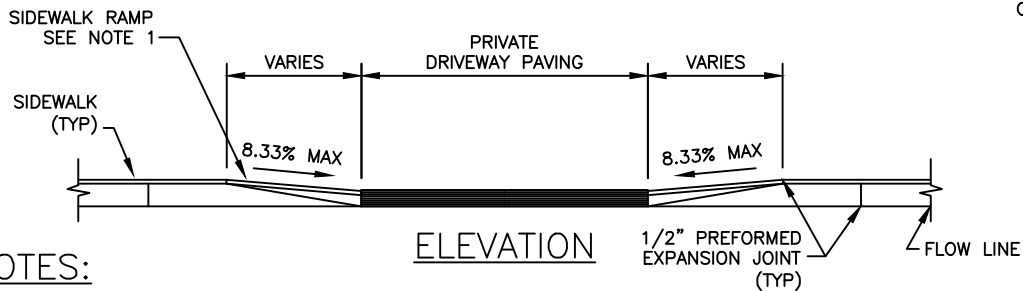

ELEVATION

NOTES:

1. ALL RAMPS SHALL HAVE A WARNING TEXTURE EXTENDING THE FULL WIDTH OF THE RAMP.
2. TIE-IN GRADE OF PRIVATE DRIVEWAY SHALL NOT EXCEED 15%.
3. PRIVATE DRIVEWAY PAVING (IF CONC, 1/2" PREFORMED EXP JT IS TO BE PROVIDED AT R/W LINE.)
4. GRASS AREA ADJACENT TO SIDEWALK MUST BE SLOPED TO MEET RAMP.

2/7/2022
Revised

5/30/2017
Approved

5/7/2007
Approved

Howard County, Maryland
Department of Public Works

Approved: *Thomas E. Butler*
Chief, Bureau of Engineering

RESIDENTIAL DRIVEWAY ENTRANCE
7" Combination Curb and Gutter
Sidewalk Abutting Curb

Detail
R-6.02

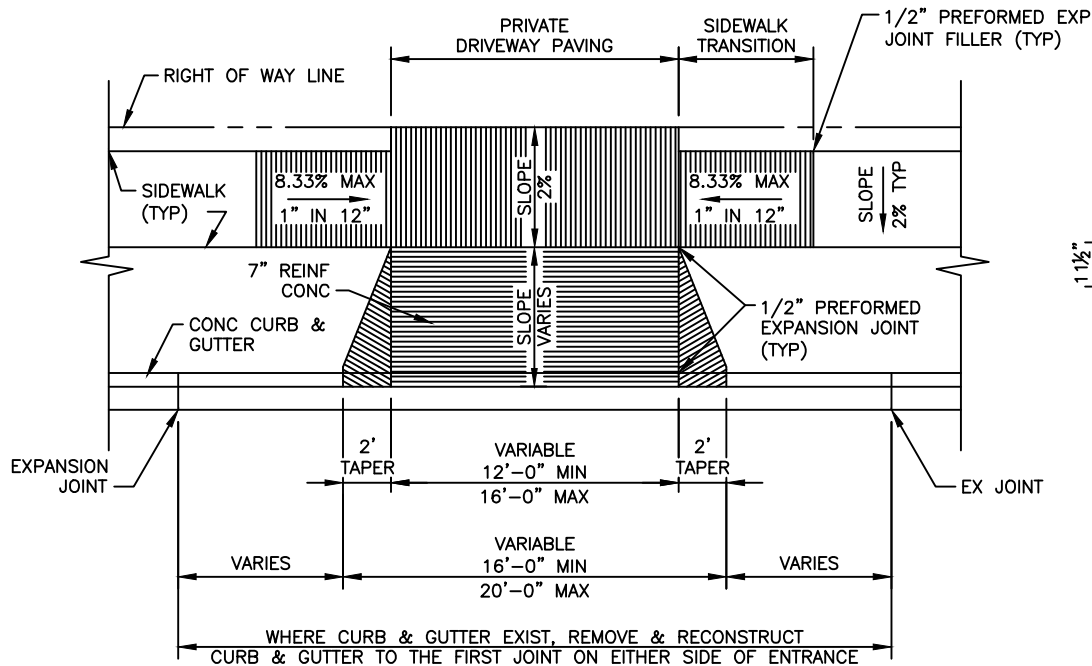

PLAN

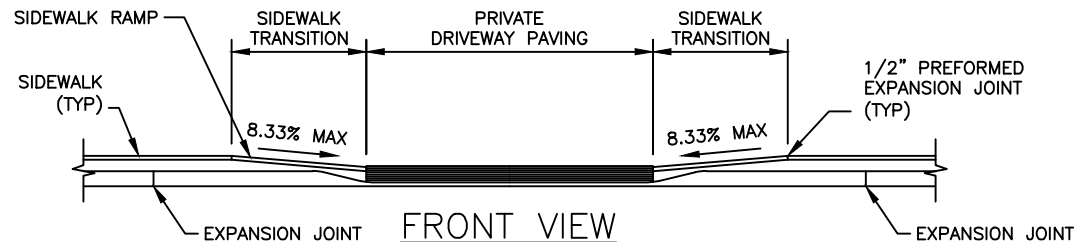

FRONT VIEW

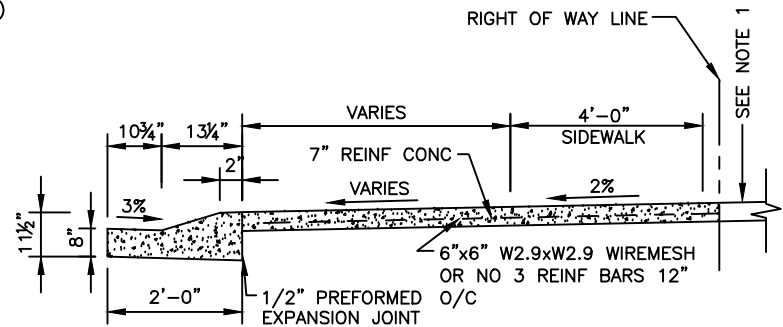

SECTION

NOTES:

1. ALL RAMPS SHALL HAVE A TEXTURE EXTENDING THE FULL WIDTH AND DEPTH OF THE RAMP.
2. PRIVATE DRIVEWAY (IF CONC, 1/2" PREFORMED EXPANSION JOINT IS TO BE PROVIDED AT THE RIGHT OF WAY LINE.)
3. TIE-IN GRADE OF PRIVATE DRIVEWAY SHALL NOT EXCEED 15%.
4. GRASS AREA ADJACENT TO SIDWALK MUST BE SLOPED TO MEET RAMP.
5. SIDWALK LESS THAN 5'-0" REQUIRES APPROVAL THROUGH THE EXCEPTIONS RPOCESS; SEE VOLUME III.
6. THE WIDTH OF THE ADJACENT SIDWALK, SHARED USE PATH, AND/OR SEPARATED BIKEWAY SHALL BE CONTINUED ACROSS THE DRIVEWAY..

 2/7/2022
 Revised
 5/30/2017
 Approved
 5/7/2007
 Approved

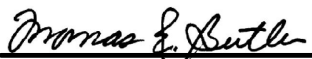
Howard County, Maryland
 Department of Public Works
 Approved: 
 Chief, Bureau of Engineering

RESIDENTIAL DRIVEWAY ENTRANCE
 Modified Combination Curb and Gutter
 Sidewalk Setback from Curb

Detail
 R-6.03

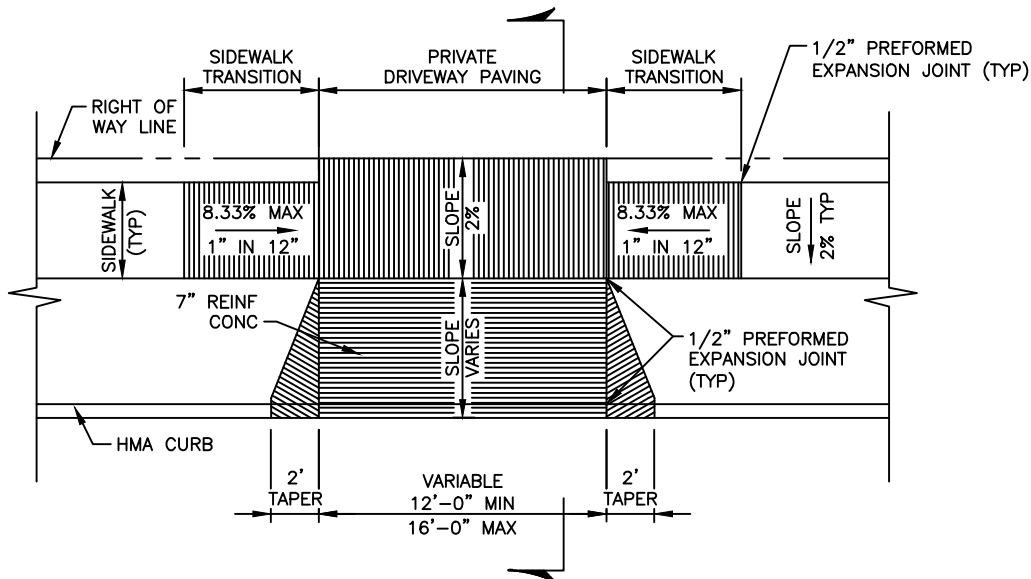

PLAN

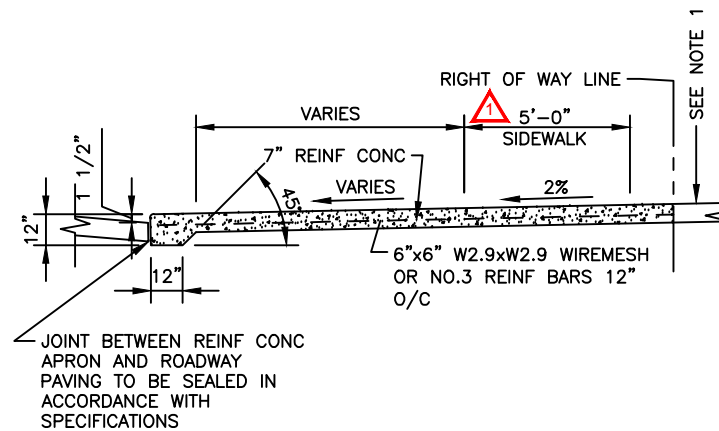

SECTION

NOTES:

1. ALL RAMPS SHALL HAVE A TEXTURE EXTENDING THE FULL WIDTH AND DEPTH OF THE RAMP.
2. PRIVATE DRIVEWAY (IF CONC., 1/2" PREFORMED EXP. JOINT FILLER IS TO BE PROVIDED AT THE RIGHT OF WAY LINE.)
3. TIE-IN GRADE OF PRIVATE DRIVEWAY SHALL NOT EXCEED 15%.
4. GRASS AREA ADJACENT TO SIDEWALK MUST BE SLOPED TO MEET RAMP.
5. SIDEWALK LESS THAN 5'-0" REQUIRES APPROVAL THROUGH THE EXCEPTIONS PROCESS; SEE VOLUME III.
6. THE WIDTH OF THE ADJACENT SIDEWALK, SHARED USE PATH, AND/OR SEPARATED BIKEWAY SHALL BE CONTINUED ACROSS THE DRIVEWAY.

 2/7/2022
 Revised
 5/30/2017
 Approved
 5/7/2007
 Approved

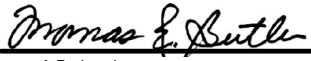
Howard County, Maryland
 Department of Public Works
 Approved: 
 Chief, Bureau of Engineering

RESIDENTIAL DRIVEWAY ENTRANCE
 Hot Mix Asphalt Curb
 Sidewalk Setback from Curb

Detail
 R-6.04

NOTES:

1. WHERE CURB & GUTTER EXISTS, REMOVE & RECONSTRUCT CURB & GUTTER TO FIRST JOINT ON EITHER SIDE OF ENTRANCE.
2. TIE-IN GRADE OF PRIVATE DRIVEWAY SHALL NOT EXCEED 15%.
3. POSITIVE DRAINAGE SHALL BE PROVIDED FROM THE PROPERTY LINE DOWN TO THE ROADWAY.
4. PROVISIONS SHALL BE MADE TO MINIMIZE CONSTRUCTION IMPACT TO PUBLIC/RESIDENTS ACCESS TO PROPERTIES

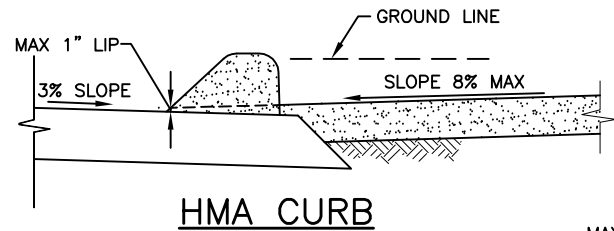
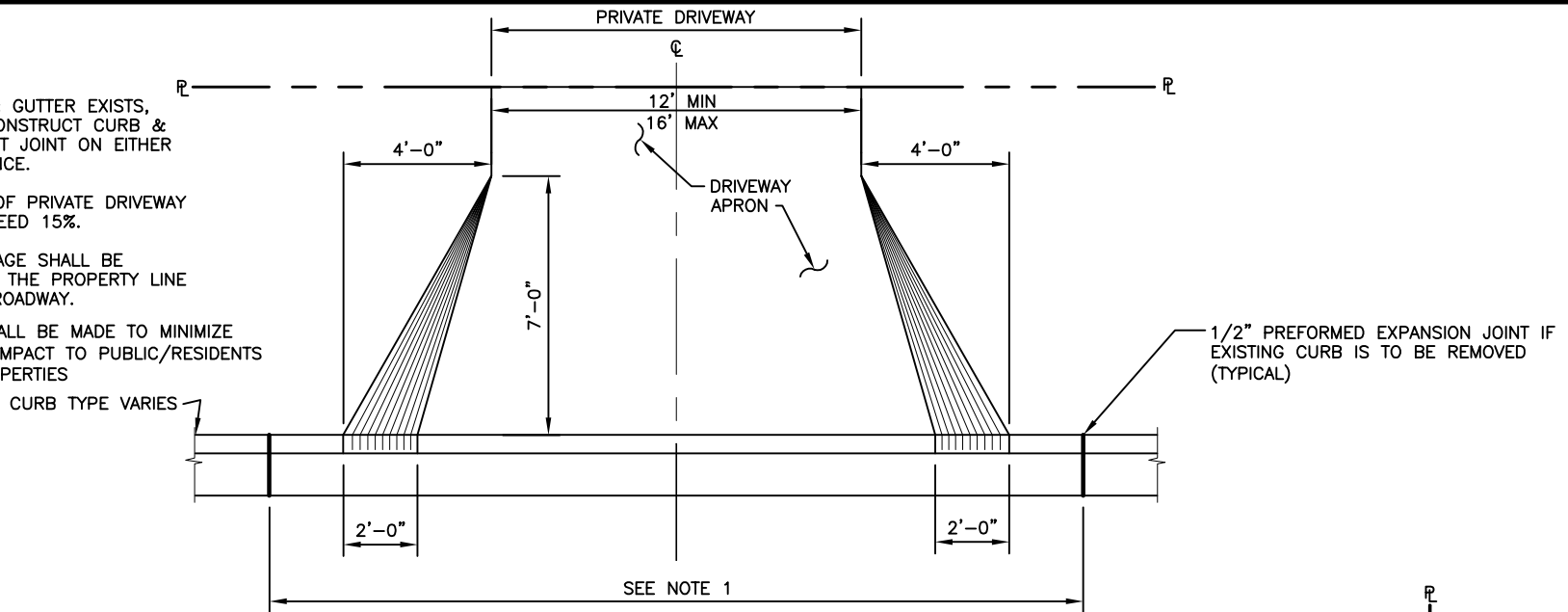

HMA CURB

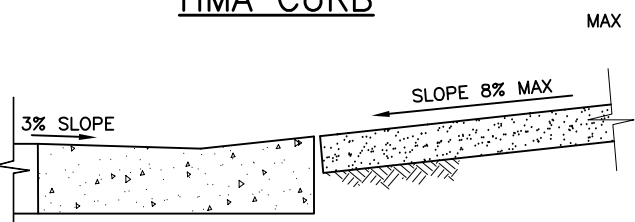

MODIFIED COMBINATION CURB AND GUTTER

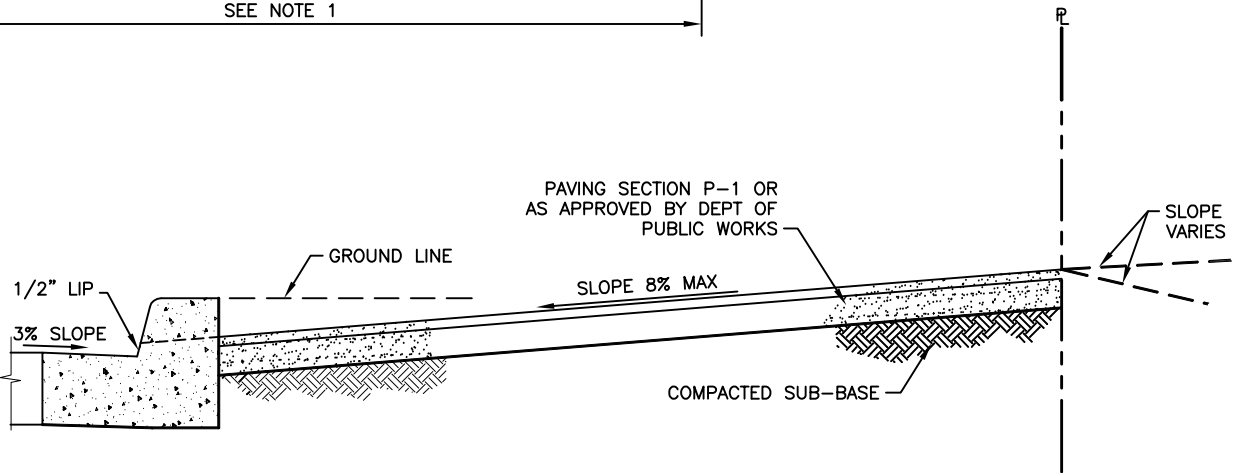

7" COMBINATION CURB AND GUTTER

Revised
 5/30/2017
 Revised
 5/7/2007
 Approved

Howard County, Maryland
 Department of Public Works
 Approved: *Momas E. Butler*
 Chief, Bureau of Engineering

RESIDENTIAL DRIVEWAY ENTRANCE
 Closed Section Roadway
 without Sidewalk

Detail
R-6.05

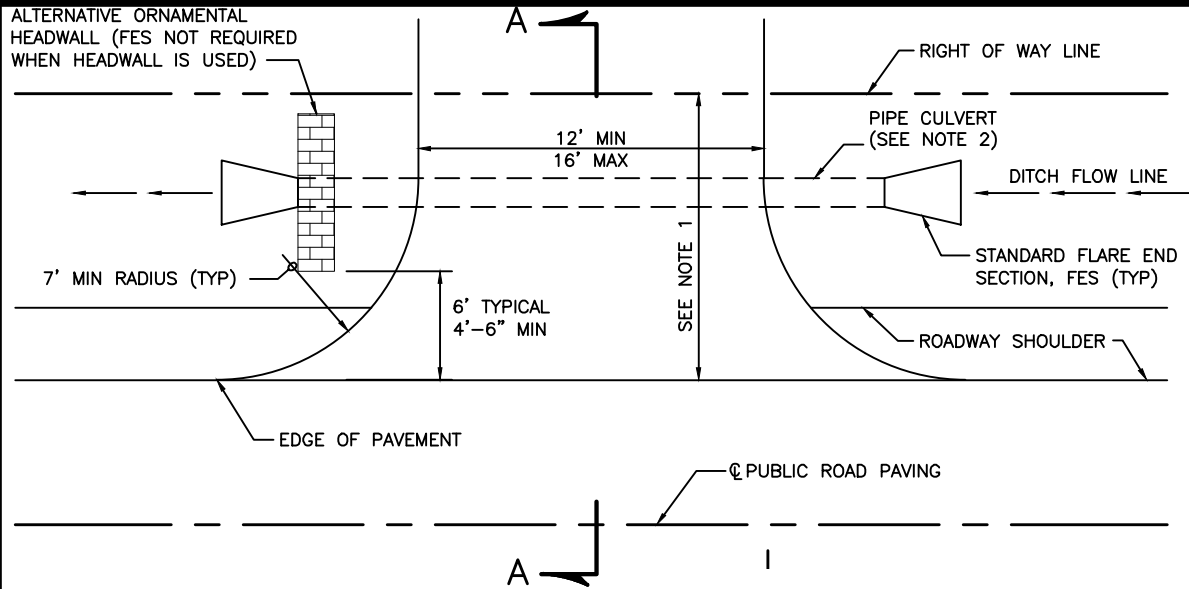

PLAN

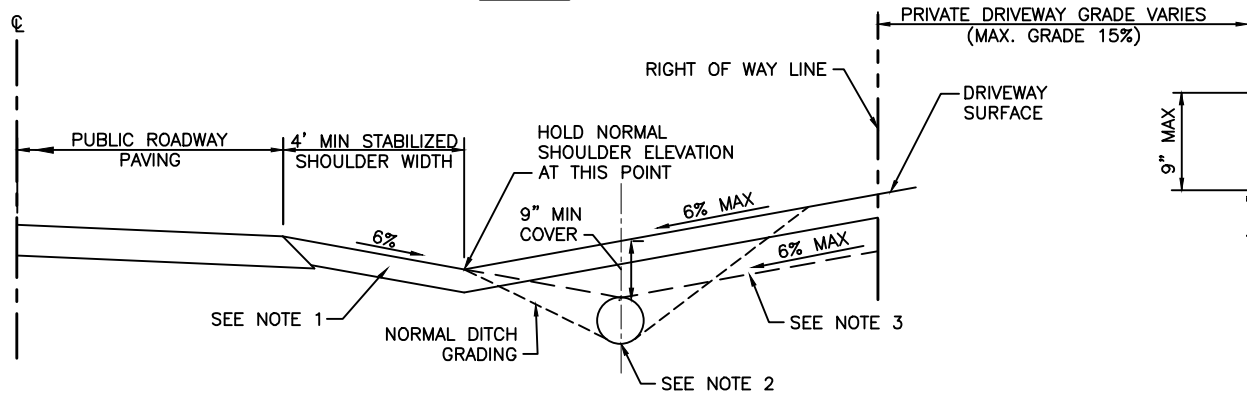

SECTION A-A

NOTES:

1. DRIVEWAY MUST BE PAVED FROM EDGE OF PUBLIC ROAD TO RIGHT OF WAY LINE USING STANDARD PAVING SECTION P-1 OR ALTERNATE SECTION EQUAL TO OR BETTER THAN P-1, AS APPROVED BY DPW.
2. DRAINAGE CULVERT SHALL BE SIZED FOR A 10 YEAR FREQUENCY STORM AND THE MINIMUM SIZE SHALL BE 12" DIA ROUND OR 14"x9" ARCH PIPE IF LARGER PIPE IS REQUIRED, DITCH INVERT SHALL BE LOWERED TO PROVIDE MIN DITCH GRADIENT OF 0.5% AND CLEARANCE SHOWN.
3. SWALE FLOW MAY BE PROVIDED OVER DRIVEWAY LOCATED AT OR NEAR THE CREST OF VERTICAL CURVES ON THE PUBLIC ROAD WHERE QUANTITY OF FLOW IS SMALL, AS APPROVED BY DPW.
4. TIE-IN GRADE OF PRIVATE DRIVEWAY SHALL NOT EXCEED 15%.
5. SEE TYPICAL SECTIONS FOR LAYOUT AND GRADING OF DITCH AND PIPE CULVERT.
6. USE OF THE ALTERNATIVE ORNAMENTAL HEADWALL SHALL REQUIRE APPROVAL BY THE DPW DIRECTOR. HOWARD COUNTY WILL NOT MAINTAIN ORNAMENTAL HEADWALLS. AN HOA AGREEMENT IS REQUIRED.

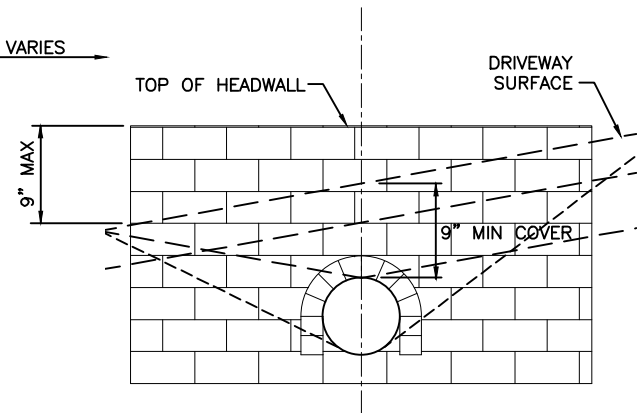

ALTERNATIVE ORNAMENTAL HEADWALL DETAIL

Revised
 5/30/2017
 Approved
 5/7/2007
 Approved

Howard County, Maryland
 Department of Public Works
 Approved: *Thomas E. Butler*
 Chief, Bureau of Engineering

RESIDENTIAL DRIVEWAY ENTRANCE
 Open Section Roadway

Detail
 R-6.06

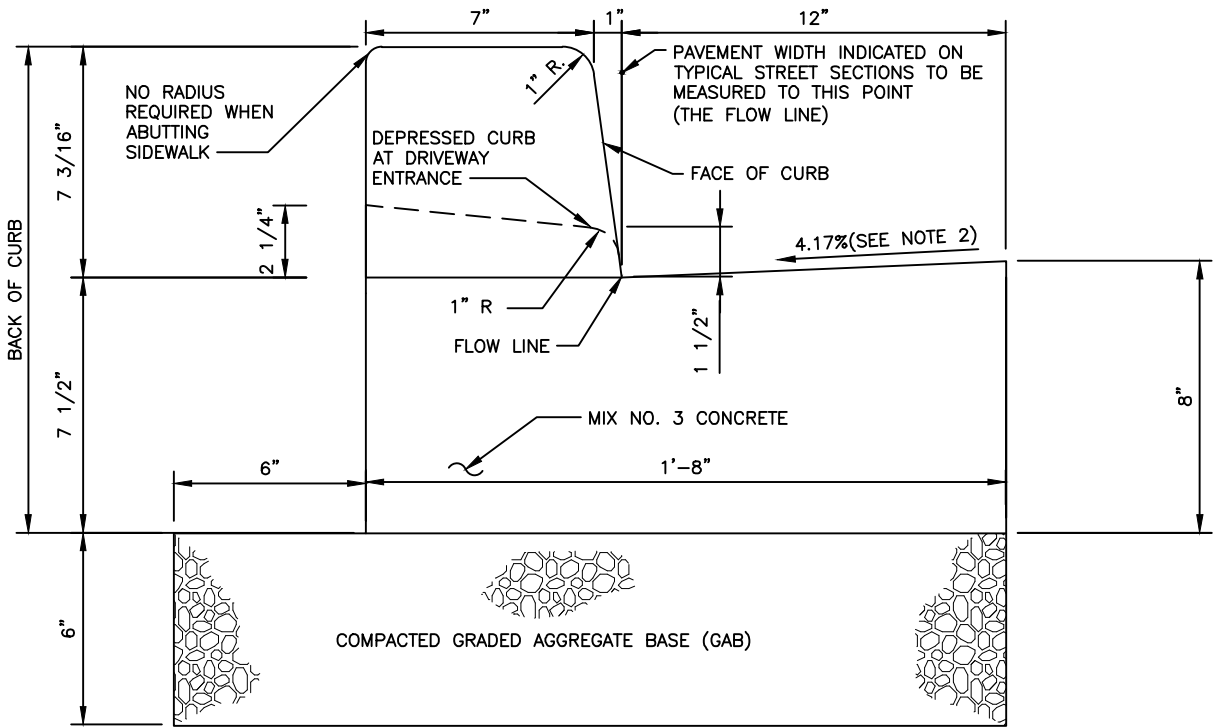

7" COMBINATION CURB AND GUTTER

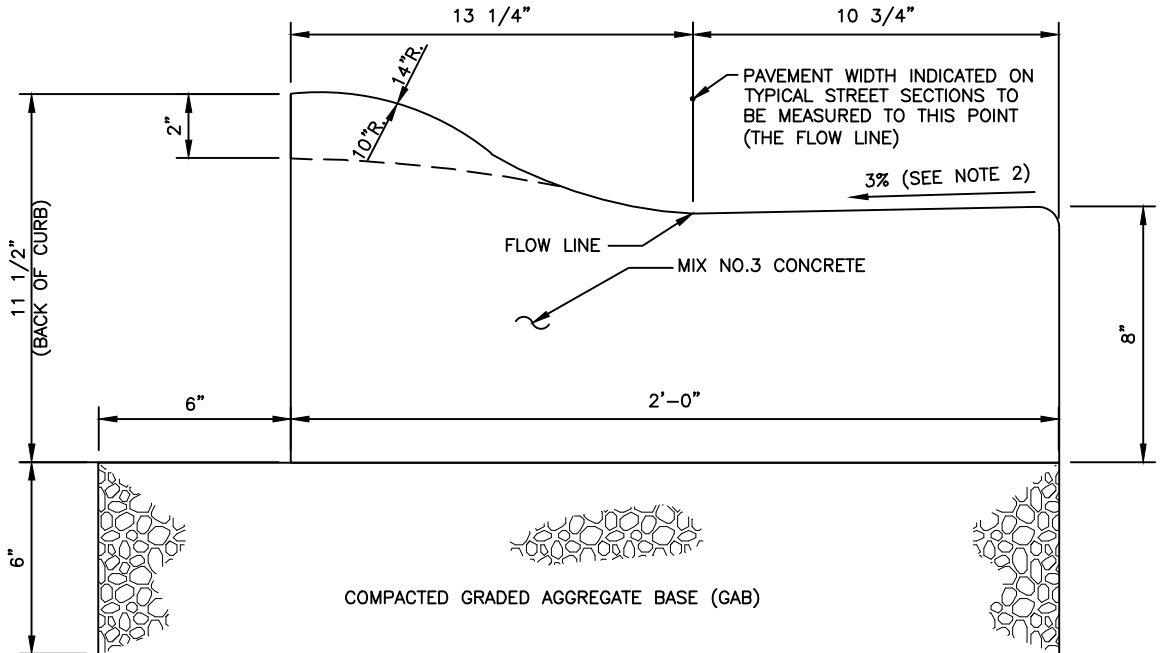

NOTE: MODIFIED COMBINATION CURB AND GUTTER

1. A REVERSE GUTTER PAN SHALL HAVE A GUTTER SLOPE OF 4.17% AWAY FROM THE FLOW LINE, AND SHALL NOT BE USED WHERE THIS DRAINAGE CREATES A HAZARDOUS CONDITION.
2. GUTTER PAN AT THE MEDIAN EDGE OF INTERMEDIATE ARTERIALS OR THE HIGH SIDE OF SUPERELEVATED SECTIONS SHALL BE SLOPED AT THE SAME RATE AND IN THE SAME DIRECTION AS THE PAVEMENT. MATCH PAVEMENT CROSS SLOPE WHEN CURB IS LOCATED ON THE LOW SIDE OF SUPERELEVATED SECTION AND THE RATE OF SUPERELEVATION IS GREATER THAN 3% FOR MODIFIED CURB & GUTTER.
3. A MINIMUM OF TWO (2) FEET OF COMPACTED STABILIZED EARTH, OR EQUIVALENT, SHALL SUPPORT THE ENTIRE BACK OF CURB.
4. POSITIVE DRAINAGE SHALL BE PROVIDED BOTH BEHIND THE CURB AND ALONG THE GUTTER AND FLOW LINE.

Revised 5/30/2017 Approved 5/7/2007 Approved	Howard County, Maryland Department of Public Works Approved: <i>Thomas E. Butler</i> Chief, Bureau of Engineering	CURB AND GUTTER 7" & Modified	Detail R-3.01
--	--	----------------------------------	------------------